

**South Plains College**  
**Intermediate Algebra (MATH 0320)**  
**Review Objectives**

**Objective 1:** Graph linear equations and write the equation of the line. (Sections 3.5, 3.6)

1. Graph.

$$9x - 6y = 18$$

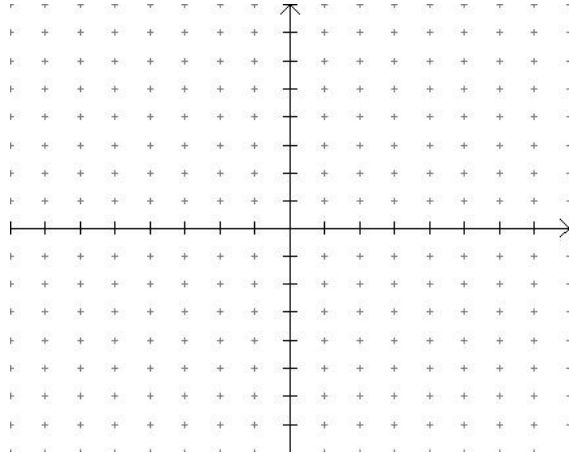

2. Graph.

$$3x + 4y = 24$$

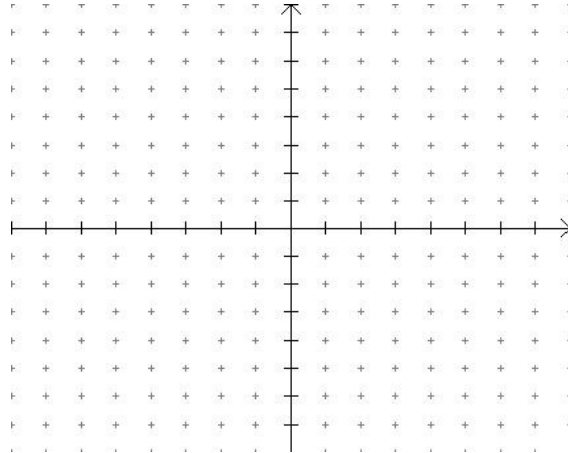

3. Graph.

$$3x - 5y = 15$$

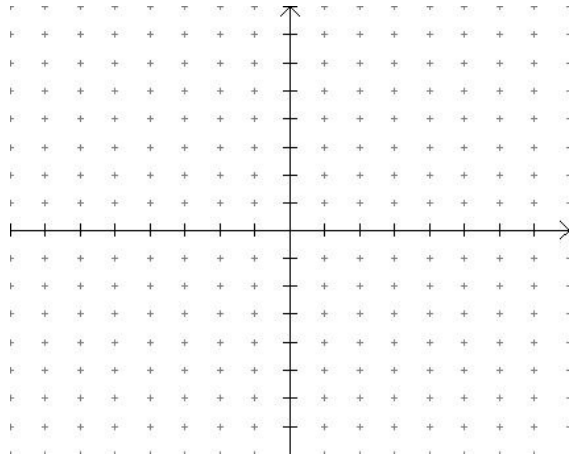

4. Graph.

$$4x - 3y = 12$$

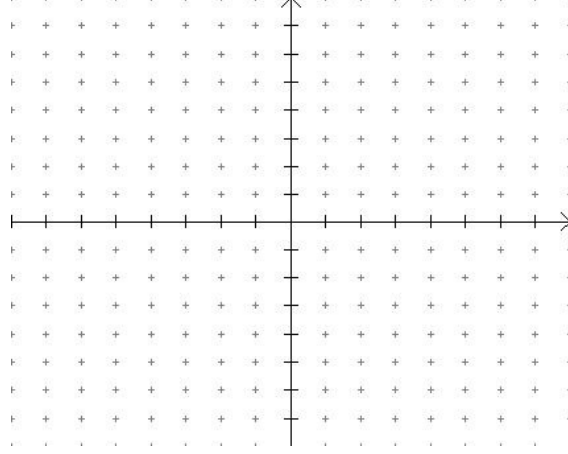

5. Using the graph find the equation of the line in slope-intercept form.

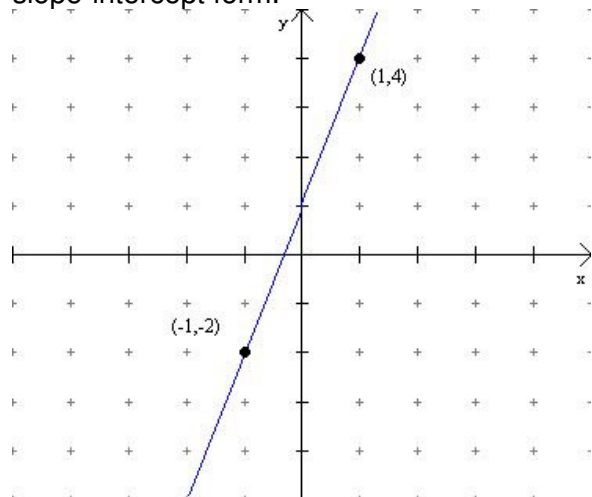

6. Using the graph find the equation of the line in slope-intercept form.

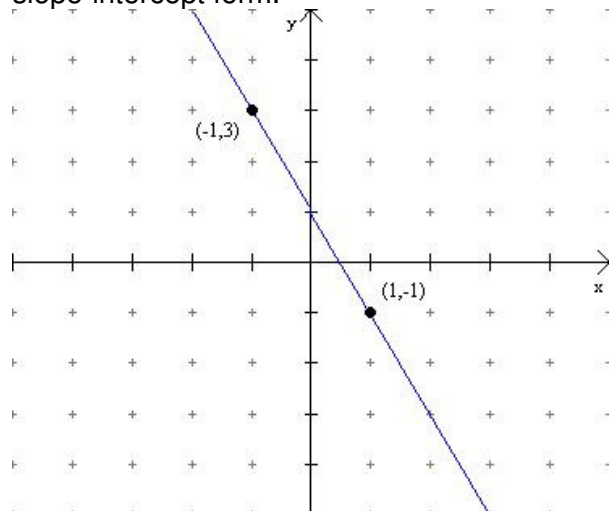

7. Using the graph, find the equation of the line in slope-intercept form.

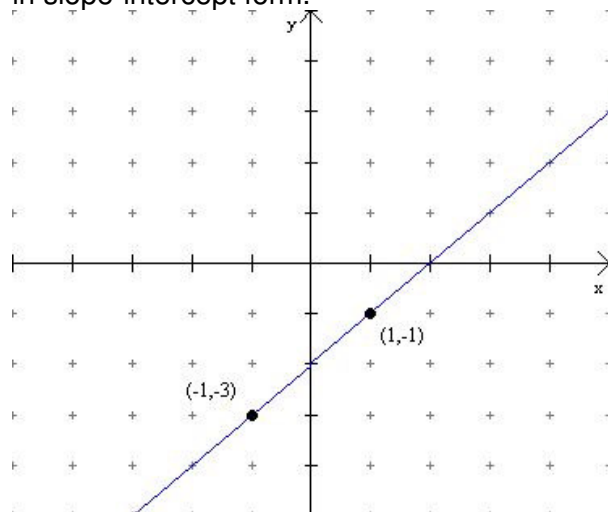

8. Find an equation of the line with the given slope and containing the given point. Express your answer in slope-intercept form.

$$m = \frac{2}{5}; (5, 1)$$

9. Find an equation of the line with the given slope and containing the given point. Express your answer in slope-intercept form.

$$m = \frac{3}{4}; (4, 1)$$

10. Find an equation of the line with the given slope and containing the given point. Express your answer in slope-intercept form.

$$m = \frac{4}{5}; (5, 3)$$

11. Find an equation of the line passing through the given points. Express your answer in slope-intercept form.

$$(2, 3); (2, -1)$$

12. Find an equation of the line passing through the given points. Express your answer in slope-intercept form.  
 $(1, 5); (-2, 5)$

13. Find an equation of the line passing through the given points. Express your answer in slope-intercept form.  
 $(4, 3); (-1, 4)$

14. Find the slope and y-intercept of the line. Graph the line.  
 $x = 3$

15. Find the slope and y-intercept of the line. Graph the line.  
 $y = 4$

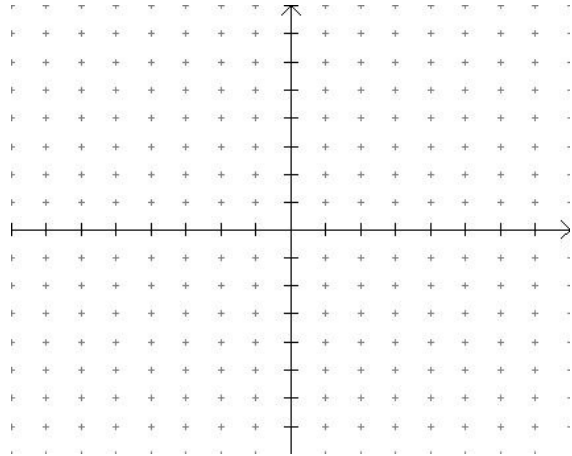
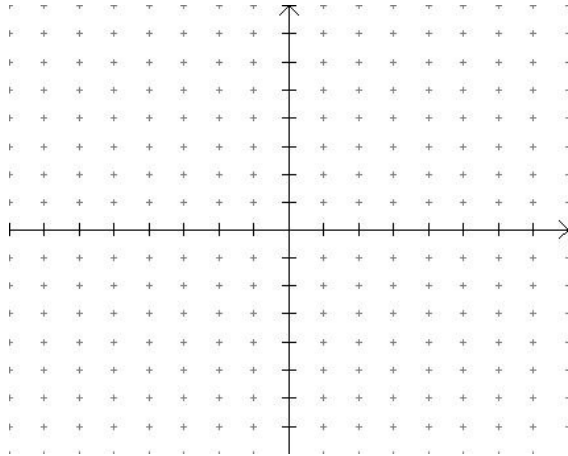

16. Find an equation of the line perpendicular to  $-2x - 5y + 5 = 0$  through the point  $(2, 1)$ . Express your answer in slope-intercept form. Graph both lines.

17. Find an equation of the line parallel to  $2x + 5y = -5$  through the point  $(5, 3)$ . Express your answer in slope-intercept form. Graph both lines.

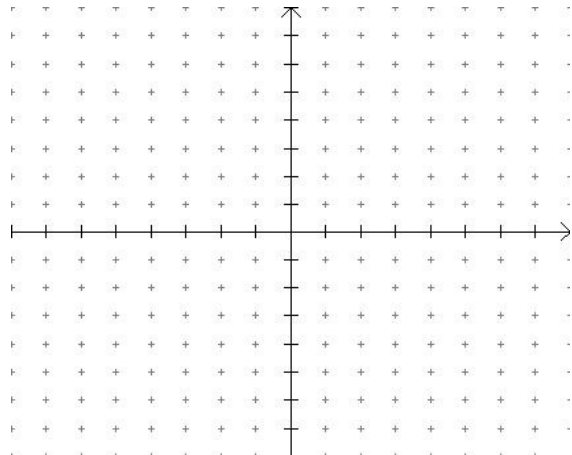
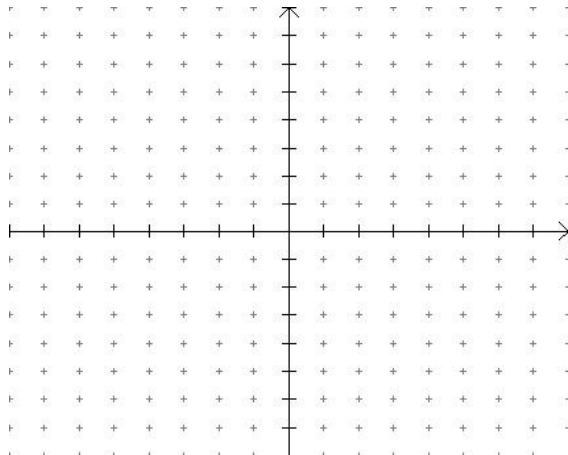

**Objective 2:** Solve systems of equations by graphing, addition (elimination), and substitution.  
 (Sections 4.1, 4.2, 4.3)

18. Use the graph of the system to determine the solution and type of system. Give the solution and label the type of system.

$$\begin{cases} x + 3y = 4 \\ x + 3y = -2 \end{cases}$$

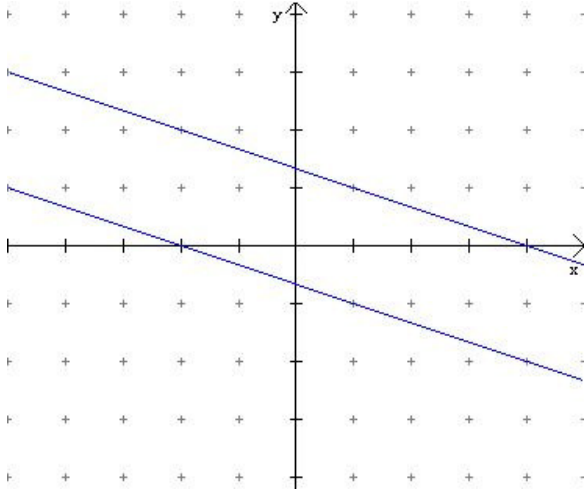

19. Use the graph of the system to determine the solution and type of system. Give the solution and label the type of system.

$$\begin{cases} 2x + y = 3 \\ 4x + 2y = 6 \end{cases}$$

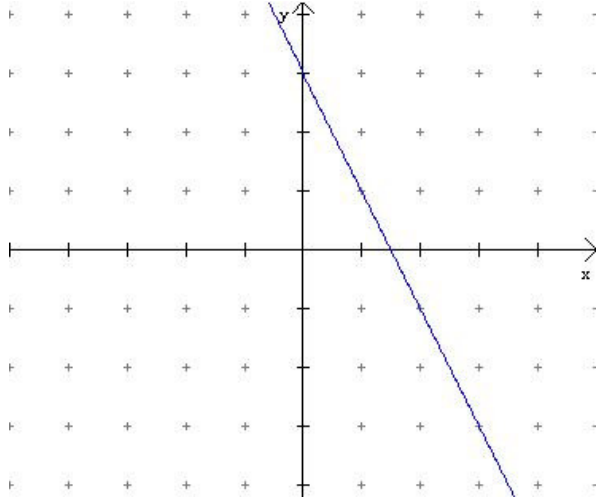

20. Solve the system of equations by graphing. Give the solution and label the type of system.

$$\begin{cases} x + 2y = 0 \\ 3x - y = 7 \end{cases}$$

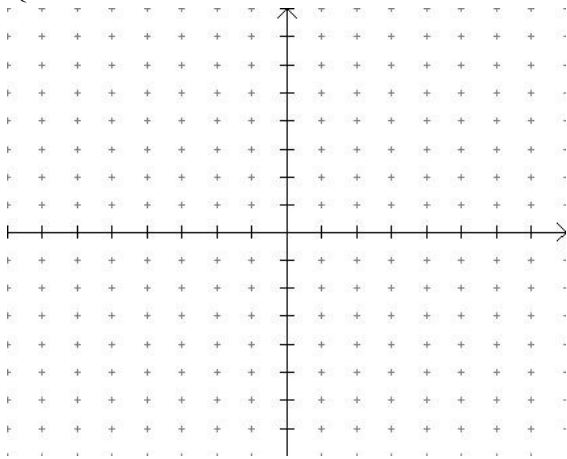

21. Solve the system by the substitution method. Give the solution and label the system.

$$\begin{cases} 3x - y = -4 \\ 9x - 3y = 11 \end{cases}$$

22. Solve the system of equations using substitution. Give the solution and label the system.

$$\begin{cases} x + 2y = 0 \\ 4x + 12y = -1 \end{cases}$$

23. Solve the system of equations using elimination. Give the solution and label the type of system.

$$\begin{cases} x + 2y = -5 \\ 3x + 4y = -7 \end{cases}$$

24. Solve the system of equations using elimination. Give the solution and label the type of solution.

$$\begin{cases} 3x + 2y = -4 \\ 6x - \frac{2}{5}y = 3 \end{cases}$$

26. Solve the system of equations using either substitution or elimination. Give the solution and label the type of solution.

$$\begin{cases} 3x + 4y = -1 \\ 4x + 5y = 0 \end{cases}$$

25. Solve the given system by the substitution method. Give the solution and label the type of solution.

$$\begin{cases} y = \frac{2}{3}x + 1 \\ 2x - 3y = -3 \end{cases}$$

27. Solve the system of equations using either substitution or elimination. Give the solution and label the type of system.

$$\begin{cases} \frac{2}{5}x - y = \frac{7}{5} \\ \frac{1}{2}x - \frac{5}{4}y = 2 \end{cases}$$

**Objective 3:** Translate and solve word problems using systems. (Sections 4.4, 4.5)

28. In the following problem, let  $x$  represent one number and let  $y$  represent the other. Use the given conditions to write a system of equations. Solve the system and find the numbers.

The sum of two numbers is 19. If the second number is subtracted from the other, the result is 3. Find the two numbers.

29. Let  $x$  represent one number and let  $y$  represent the other. Use the given conditions to write a system of equations. Solve the system and find the numbers.

Two numbers sum to 51. Twice the first subtracted from the second is 9. Find the numbers.

30. Suppose John ate two steak and cheese sandwiches and three chocolate chip cookies for lunch for a total of 1342 calories. Sarah has lunch with John and eats one steak and cheese sandwich and two chocolate chip cookies for a total of 777 calories. How many calories are in a steak and cheese sandwich? How many calories are in a chocolate chip cookie?

31. The perimeter of a rectangular floor is 80 feet. If the length is 16 feet more than the width, what are the dimensions of the floor? (Hint:  $P=2l+2w$  is the formula for perimeter.)

32. A plane can fly 1140 miles in 6 hours with a tail wind. Against this same wind, the plane can fly 540 miles in 6 hours. Find the airspeed of the plane. What is the impact of the wind on the plane?

33. A store sells cashews for \$6.00 per pound and peanuts for \$3.00 per pound. The manager decides to mix 80 pounds of peanuts with some cashews and sell the mixture for \$4.00 per pound. How many pounds of cashews should be mixed with the peanuts so that the mixture will produce the same revenue as would selling the nuts separately?

34. Suppose that you received an unexpected inheritance of \$33,750. You have decided to invest the money by placing some of the money in stocks and some in bonds. To diversity, you decided that five times the amount in bonds should equal four times the amount invested in stocks. How much should be invested in stocks? How much should be invested in bonds?

35. A store sells walnuts for \$5.50 per pound and pecans for \$7.85 per pound. The foods manager decides to mix the two nuts for a holiday mixture and sell the mix for \$6.00 per pound. By setting the mixture's price at \$6.00, the manager does not want any revenue loss compared to selling the nuts separately. How many pounds of walnuts and pecans should be mixed to accomplish this task and create 50 pounds of holiday mix? Round your answer to the nearest tenth of a pound.

36. A small airplane can fly 320 miles in two hours against the wind. With a tail wind the airplane can fly 360 miles in two hours. What are the airspeed of the plane and the impact of the wind on the plane?

37. Car A travels at an average speed of 50 miles per hour. Car B travels at an average speed of 40 miles per hour. In the time it takes car B to travel a certain distance  $d$ , car A travels 80 miles farther. Find the distance that each car travels and the time of its trip.

**Objective 4:** Graph systems of inequalities. (Sections 3.8, 4.6)

38. Graph the system of linear inequalities.

$$\begin{cases} x - \frac{1}{3}y < \frac{2}{3} \\ 2x + y \geq 1 \end{cases}$$

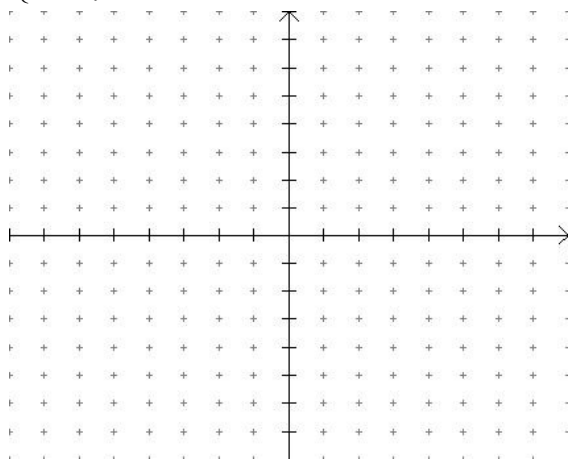

39. Graph the system of linear inequalities.

$$\begin{cases} 3x + y < 12 \\ -3x - y > -12 \end{cases}$$

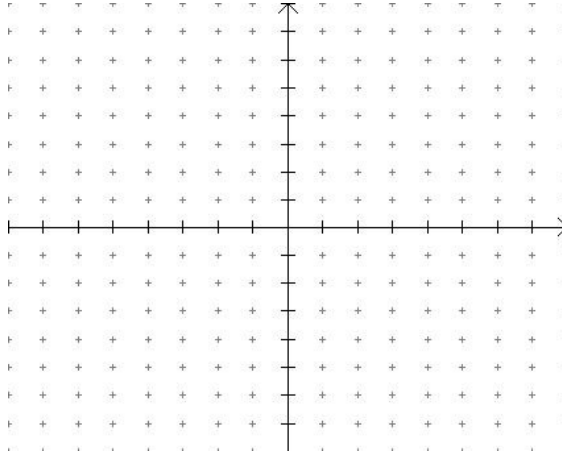

**Objective 5:** Factor polynomials. (Section 6.5)

40. Factor completely.

$$7x^2 - 14x - 105$$

41. Factor completely.

$$16x^2 - 25$$

42. Factor completely.

$$8x^3 + 27$$

43. Factor the polynomial completely.

$$2y^2 - 98$$

44. Factor the polynomial completely.

$$6z^2 + 13z - 28$$

45. Factor the polynomial completely.

$$x^3 - 5x^2 + 2x - 10$$

46. Factor the polynomial completely.

$$a^2 + 4a + 4 - 9b^2$$

47. Factor the polynomial completely.

$$2x - 8x^3$$

**Objective 6:** Solve quadratic equations by factoring. (Section 6.6)

48. Solve.

$$(x+2)(x-7) = 0$$

49. Solve.

$$-9x(2x-7) = 0$$

50. Solve.

$$3x^2 + 12x = 0$$

51. Solve.

$$p^2 - 3p - 40 = 0$$

52. Solve.

$$4x^2 = -13x - 10$$

53. Solve.

$$(x+5)(x-11)(3x+2) = 0$$

**Objective 7:** Simplify by adding, subtracting, multiplying, and dividing rational expressions. (Sections 7.1, 7.2, 7.3, 7.4, 7.5)

54. Simplify.

$$\frac{3x-15}{x^3-5x^2}$$

55. Simplify.

$$\frac{y^2+9y+14}{y^2+2y-35}$$

56. Simplify.

$$\frac{x^2-5x-6}{2x^3+16x^2+14x}$$

57. Simplify.

$$\frac{x^2+6xy+8y^2}{x^2-xy-6y^2}$$

58. Simplify.

$$\frac{3x}{x^2-3x-4} \cdot \frac{x-4}{18x^2}$$

59. Simplify.

$$\frac{m^2-n^2}{3m-3n} \cdot \frac{6}{2m+2n}$$

60. Simplify.

$$\frac{3x^2 - 6x}{x^2 - 2x - 8} \div \frac{x - 2}{x + 2}$$

62. Simplify.

$$\frac{2x}{8x - 12} - \frac{3}{2x + 2}$$

64. Simplify.

$$\frac{3x^2 - 8x - 9}{x^2 - 5x - 14} - \frac{2x^2 - 3x + 5}{x^2 - 5x - 14}$$

66. Simplify

$$\frac{x - 1}{x^2 - 36} - \frac{x}{x^2 - 12x + 36}$$

68. Simplify.

$$\frac{x + 1}{x - 3} + \frac{x - 2}{x + 2} - \frac{x^2 + 3}{x^2 - x - 6}$$

61. Simplify.

$$\frac{x^2 y}{2x^2 - 5xy + 2y^2} \div \frac{(2xy^2)^2}{2x^2 y - xy^2}$$

63. Simplify.

$$\frac{3x}{x - 6} + \frac{4}{x - 6}$$

65. Simplify.

$$\frac{3x}{x - 4} + \frac{2}{4 - x}$$

67. Simplify.

$$\frac{x + 1}{x^2 + 4x + 4} + \frac{3}{x^2 + x - 2}$$

69. Simplify.

$$\frac{y + 7}{y - 3} - \frac{y - 4}{y + 1}$$

**Objective 8:** Solve rational equations. (Section 7.7)

70. Solve.

$$\frac{3}{x} - \frac{1}{2x} = -\frac{5}{6}$$

72. Solve.

$$\frac{2}{x - 7} = \frac{-7}{x + 6}$$

74. Solve

$$1 + \frac{6}{x + 7} = \frac{9}{x - 7}$$

71. Solve.

$$\frac{a}{2a - 2} - \frac{2}{3a + 3} = \frac{5a^2 - 2a + 9}{12a^2 - 12}$$

73. Solve.

$$6p - \frac{2}{p} = 1$$

75. Solve

$$\frac{7}{x + 3} + \frac{9}{x - 6} = \frac{5x + 62}{x^2 - 3x - 18}$$

76. Solve.

$$\frac{3}{x-1} - \frac{2}{x+8} = \frac{x^2 + 16x + 10}{x^2 + 7x - 8}$$

**Objective 9:** Simplify by adding, subtracting, multiplying, and dividing radical expressions.  
(Sections 9.1, 9.2, 9.3, 9.4, 9.5, 9.6)

77. Simplify.

$$\sqrt[3]{4^3}$$

78. Simplify.

$$-125^{\frac{1}{3}}$$

79. Simplify.

$$9^{\frac{3}{2}}$$

80. Simplify.

$$125^{\frac{2}{3}}$$

81. Rewrite the following radical with a rational exponent.

$$\sqrt[3]{6y}$$

82. Rewrite the following radical with a rational exponent.

$$\sqrt[7]{x^3}$$

83. Simplify.

$$\sqrt{18}$$

84. Simplify.

$$\sqrt[3]{40}$$

85. Simplify.

$$\sqrt{8a^3b^6}$$

86. Simplify.

$$\sqrt{6} \cdot \sqrt{150}$$

87. Simplify.

$$\sqrt[5]{16x^4y^3} \cdot \sqrt[5]{6x^2y^2}$$

88. Simplify.

$$\sqrt{\frac{6}{25}}$$

89. Simplify

$$\frac{7}{\sqrt{3}}$$

90. Simplify.

$$\frac{\sqrt{63}}{\sqrt{7}}$$

91. Simplify.

$$\frac{\sqrt{240y^{11}}}{\sqrt{5y^5}}$$

92. Simplify.

$$5\sqrt{5x} - 3\sqrt{5x} + 8\sqrt{5x}$$

93. Simplify.

$$\sqrt{8} + 5\sqrt{2}$$

94. Simplify.

$$\sqrt{5x}(3 - \sqrt{35x})$$

95. Simplify.

$$(7 - 5\sqrt{6})(5 + 4\sqrt{6})$$

96. Simplify.

$$(5\sqrt{7} + \sqrt{2})(2\sqrt{7} - 3\sqrt{2})$$

97. Simplify.

$$\sqrt{32x^7} - x\sqrt{2x^5} + 4\sqrt{18x^7}$$

98. Simplify.

$$3\sqrt{28} + 6\sqrt{112}$$

99. Simplify.

$$\frac{4}{\sqrt{3} - 1}$$

100. Simplify.

$$\frac{\sqrt{5}}{\sqrt{35} - \sqrt{15}}$$

**Objective 10:** Solve radical equations. (Section 9.8)

101. Solve.

$$\sqrt[3]{2t + 97} = 5$$

102. Solve.

$$\sqrt{8x - 7} - 7 = 0$$

103. Solve.

$$\sqrt{6x + 3} = \sqrt{5x + 6}$$

104. Solve.

$$\sqrt{x + 2} - \sqrt{x - 3} = 1$$

105. Solve.

$$(4x+20)^{\frac{1}{2}} = 6$$

**Objective 11:** Add, subtract, multiply, and divide complex numbers. (Section 9.9)

106. Simplify.

$$8 + \sqrt{-36}$$

107. Simplify.

$$\frac{12 - \sqrt{-20}}{2}$$

108. Simplify.

$$(3 - \sqrt{-81}) - (7 + \sqrt{-36})$$

109. Simplify.

$$8i(4 - 9i)$$

110. Simplify.

$$(-5 + 6i)(6 - 5i)$$

111. Simplify.

$$(4 + 6i)^2$$

112. Simplify.

$$(\sqrt{-4})(\sqrt{-36})$$

113. Simplify.

$$(6 + \sqrt{-16})(-3 - \sqrt{-81})$$

114. Simplify.

$$\frac{2 + 9i}{9 - 2i}$$

115. Simplify.

$$\frac{5 - 5i}{8i}$$

**Objective 12:** Solve quadratic equations by square root property, completing the square, and the quadratic formula. (Sections 10.1, 10.2)

116. Solve by using the Square Root Property.

$$3x^2 = 48$$

117. Solve by using the Square Root Property.

$$(2p + 3)^2 = 16$$

118. Solve by completing the square.

$$b^2 + 10b + 19 = 0$$

119. Solve by completing the square.

$$z^2 - 3z + 5 = 0$$

120. Solve by completing the square.

$$2x^2 + 4x + 5 = 0$$

121. Solve by completing the square.

$$3m^2 + 2m - 7 = 0$$

122. Solve by using the Quadratic Formula.

$$4m^2 - 8m + 1 = 0$$

123. Solve by using the Quadratic Formula.

$$9y^2 - 6y + 1 = 0$$

124. Solve by using the Quadratic Formula.

$$3x^2 + 5x = 8$$

125. Solve by using the Quadratic Formula.

$$8p^2 - 40p + 50 = 0$$